

cimPRESS Full Port Ball Valve

cim221.1

CimPRESS x FIPT

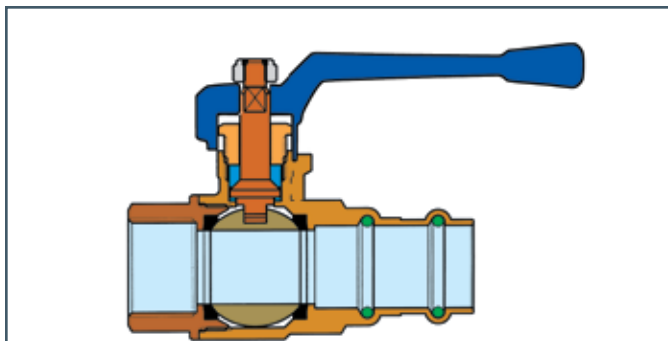
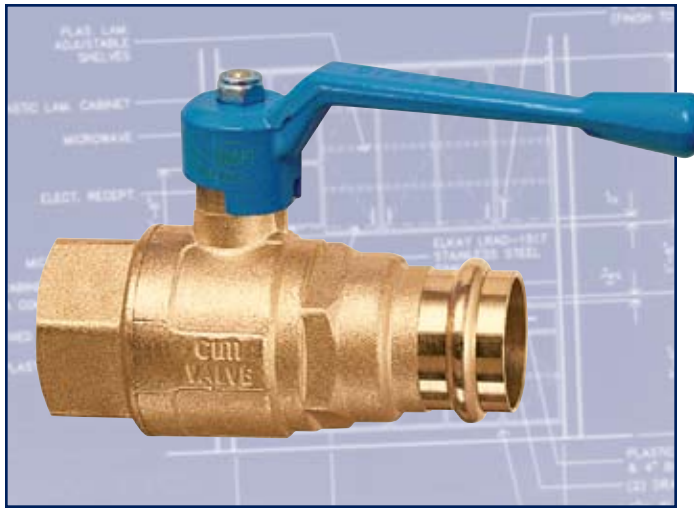

Materials:

- Body: Hot Forged Brass ASTM C37700
- Ball: Brass, Machined to a Micro-Smooth Finish, Hard Chromium Plated
- Ball Seats: Conical Rings in P.T.F.E.
- Stem Seal: Rings in P.T.F.E.
- O-Ring: EPDM - ASTM D 2000 M2
- Handle: Aluminum
- Nut: Self-Locking Type, Steel ANSI C.1008.

All Cimberio valves qualify for the American Recovery and Reinvestment Act and the Buy American Act.

Applications:

The CIM 221.1 CimPRESS ball valve is manufactured in accordance with MSS-SP-110, PS117-2004, and EN ISO 9001 standards and is designed for direct connection to hard drawn copper and/or stainless steel tube using standard press tools. The CIM 221.1 is suitable for use with non-aggressive fluid applications including residential, industrial, and agricultural systems. (CimPRESS is not intended for use with soft or rolled copper tubing)

Features:

CimPRESS valves were developed as purpose built valves for standard press attachment to eliminate the need to assemble separate components in the field, which could result in weak/leak points and increased material and labor costs. The CIM 221.1 is manufactured from DZR "CR" corrosion-resistant brass with double EPDM-ASTM D 2000 M2 O-Rings to ensure a leak proof cold crimped seal with added protection against corrosion.

CimPRESS valves eliminate the torch and the need to clean, flux and solder in order to create a permanent watertight valve connection, significantly reducing average installation time while avoiding potential fire risks and other problems associated with sweat connections; saving time and money.

Connection:

Standard press connection for copper and stainless steel tube plumbing systems x NPT threads ANSI B 1.20.1

Size	Fast Order No.	Technical ID No.
1/2"	221-04	CIM221-AE04LH
3/4"	221-06	CIM221-AE06LH
1"	221-07	CIM221-AE07LH
1-1/4"	221-08	CIM221-AE08LH
1-1/2"	221-09	CIM221-AE09LH
2"	221-10	CIM221-AE10LH

cimPRESS Full Port Ball Valve

cim221.1

CimPRESS x FIPT

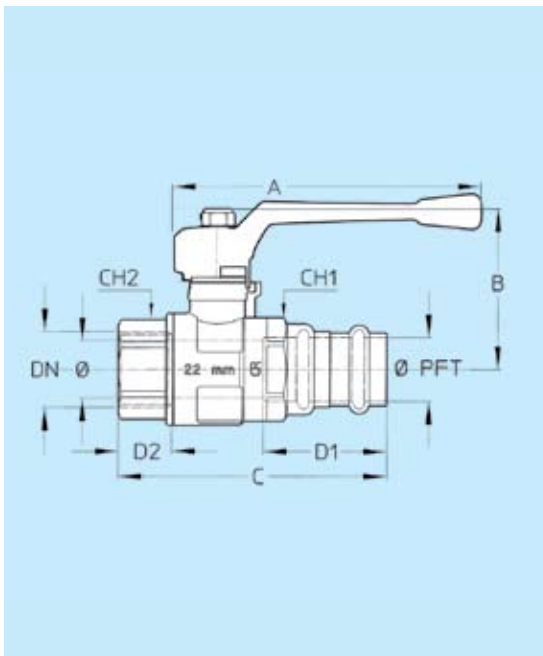

Size	1/2"	3/4"	1"	1-1/4"	1-1/2"	2"
Port inch	0.59"	0.79"	0.98"	1.26"	1.57"	1.97"
Port mm	15mm	20mm	25mm	32mm	40mm	50mm
A	3-15/16"	5-1/2"	5-1/2"	6-5/8"	7-7/8"	7-7/8"
	100mm	140mm	140mm	170mm	200mm	200mm
B	2-1/16"	2-3/16"	2-3/8"	2-7/8"	3-1/2"	3-3/4"
	52mm	56mm	60mm	72.5mm	88.5mm	95.5mm
C	3-5/16"	3-11/16"	4-1/8"	4-7/16"	5-1/8"	6"
	83.5mm	94mm	105mm	112.5mm	131mm	152.5mm
D1	1-9/16"	1-3/4"	1-3/4"	1-11/16"	1-15/16"	2-1/8"
	40mm	44mm	44mm	43mm	48.5mm	54.5mm
D2	11/16"	3/4"	13/16"	7/8"	15/16"	1-1/16"
	17mm	18.5mm	21mm	22.5mm	23mm	26.5mm
CH1	15/16"	1-1/4"	1-1/2"	1-7/8"	2-3/16"	2-11/16"
	24mm	32mm	38mm	48mm	55mm	68mm
CH2	1"	1-1/4"	1-9/16"	1-15/16"	2-3/16"	2-3/4"
	25mm	31mm	40mm	49mm	55mm	69mm
Pounds	0.53	0.88	1.31	2.06	3.01	4.52
Grams	240	400	595	935	1365	2050
Required Pipe Insertion Depth	1.5580"	1.7380"	1.7310"	1.6975"	1.8895"	2.128"
	39.57mm	44.14mm	43.97mm	43.12mm	47.99mm	54.04mm

FLOW AND PRESSURE DROP

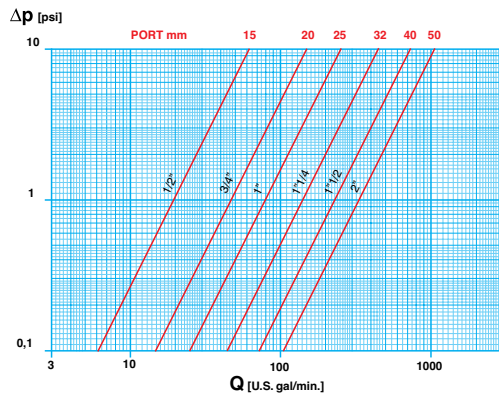

PRESSURE/TEMPERATURE RATINGS

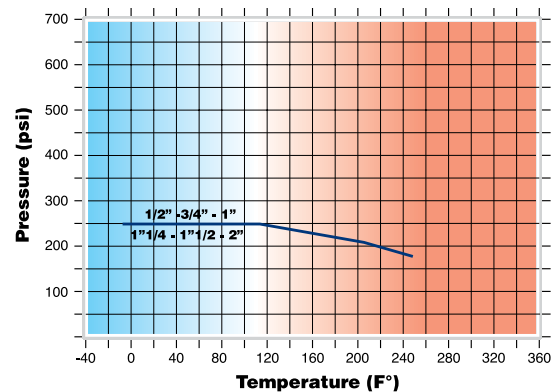

CV CM CS MT

CV: Capacity in "U.S. gal/min" at pressure drop of "1 PSI"

CM: Working Torque in "lb x in"

CS: Starting Torque in "lb x in"

MT: Torque Breaking Point on the Stem in "lb x in"

Element: Water - Temperature: 59.9° F

	SIZE	1/2"	3/4"	1"	1-1/4"	1-1/2"	2"
221.1	Ø mm	15	20	25	32	40	50
	Ø inch	0.59	0.79	0.98	1.26	1.57	1.97
CV	gal/min	19.7	47.5	78.7	142.3	229.1	335.4
CM	N x m	3	5	6	7	10	13
	lb x in	27	44	53	62	89	115
CS	N x m	6	10	12	14	20	26
	lb x in	53	89	106	124	177	230
MT	N x m	10	24	24	45	90	90
	lb x in	89	213	213	399	797	797

Working Pressure: 250 PSI

Max. Operating Temperature: Working Limit for Fluids -4° F – 248° F

Test Pressures: According to ISO 5208