

Full Port Heavy Pattern Ball Valve

cim 11.1

Flat Handle • FIPT x FIPT • UL/CSA/AGA Listed



Applications:

The CIM 11.1 ball valve is manufactured in accordance with EN ISO 9001 and is designed for use with non-aggressive fluids and gases. Applications include: residential and commercial plumbing, industrial applications, agricultural systems, waterworks, saturated steam or high temperature hot water services, condensate lines, as well as oil, gasoline and other hydrocarbon services.

Features:

The CIM 11.1 ball valve, which is the building block for many other Cimberio valves, is a full port ball valve built with a heavy pattern body that offers increased thread depth and includes a unique blast proof/impact proof 3 part stem design that allows handle option flexibility. The standard CIM 11.1 is equipped with a corrosion resistant coated flat steel handle with a PVC grip. Tee, locking, nylon isolation, and slow closure handles are also available.

Threading:

NPT threads ANSI B1.20.1.

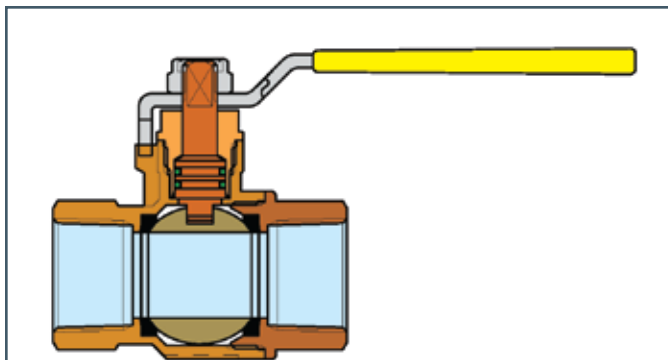

Materials:

- **Body:** Hot Forged Brass ASTM C37700
- **Adaptor:** Hot Forged Brass ASTM C37700
- **Ball:** Brass, Machined to a Micro-Smooth Finish, Hard Chromium Plated
- **Cap Stem:** 36600 Bar Stock
- **Ball Seats:** Conical Rings in P.T.F.E.
- **Stem Seal:** Two O-Rings in FPM.
- **Handle:** Corrosion Coat Rugged Steel with PVC Grip
- **Nut:** Self-Locking Type, Steel ANSI C.1008.

All Cimberio valves qualify for the American Recovery and Reinvestment Act and the Buy American Act.

Size	Fast Order No.	Technical ID No.
1/4"	11-02	CIM11-A02FH
3/8"	11-03	CIM11-A03FH
1/2"	11-04	CIM11-A04FH
3/4"	11-06	CIM11-A06FH
1"	11-07	CIM11-A07FH
1-1/4"	11-08	CIM11-A08FH
1-1/2"	11-09	CIM11-A09FH
2"	11-10	CIM11-A10FH
2-1/2"	11-11	CIM11-A11FH
3"	11-12	CIM11-A12FH
4"	11-14	CIM11-A14FH

Full Port Heavy Pattern Ball Valve

cim 11.1

Flat Handle • FIPT x FIPT • UL/CSA/AGA Listed

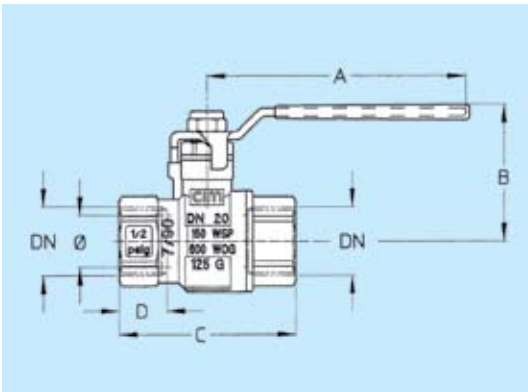

Size Port inch Port mm	1/4" 0.39" 10mm	3/8" 0.39" 10mm	1/2" 0.59" 15mm	3/4" 0.79" 20mm	1" 0.98" 25mm	1-1/4" 1.26" 32mm	1-1/2" 1.57" 40mm	2" 1.97" 50mm	2-1/2" 2.48" 63mm	3" 2.99" 76mm	4" 3.94" 100mm
A	2-9/16" 65mm	2-9/16" 65mm	3-1/8" 80mm	3-15/16" 100mm	3-15/16" 100mm	4-3/4" 120mm	5-15/16" 150mm	5-15/16" 150mm	9-7/16" 240mm	9-7/16" 240mm	12-1/4" 310mm
B	1-3/8" 34mm	1-3/8" 34mm	1-13/16" 46mm	2-1/16" 53mm	2-1/4" 57mm	2-5/8" 66mm	3-3/16" 81mm	3-7/16" 88mm	5-5/16" 134mm	5-15/16" 150mm	7-1/8" 180mm
C	7/8" 47mm	7/8" 47mm	2-7/16" 61mm	2-11/16" 68mm	3-1/4" 82mm	3-5/8" 92mm	4-1/4" 107mm	4-15/16" 125mm	5-15/16" 151mm	6-3/4" 171mm	8-1/8" 206mm
D	1/2" 12.5mm	1/2" 12.5mm	11/16" 17mm	3/4" 18.5mm	13/16" 21mm	7/8" 22.5mm	15/16" 23mm	1-1/16" 26.5mm	1-1/16" 27mm	1-1/8" 28mm	1-3/8" 35mm
CH	13/16" 20mm	13/16" 20mm	1" 25mm	1-1/4" 31mm	1-9/16" 40mm	1-15/16" 49mm	2-3/16" 55mm	2-3/4" 69mm	3-3/8" 86mm	3-15/16" 100mm	4-7/8" 123mm
Pounds	0.26	0.26	0.49	0.79	1.3	2.02	2.99	4.54	9.38	13.69	22.05
Grams	120	120	220	360	590	915	1355	2060	4255	6210	10,000

CV CM CS MT

CV: Capacity in "U.S. gal/min" at pressure drop of "1 PSI"

CM: Working Torque in "lb x in"

CS: Starting Torque in "lb x in"

MT: Torque Breaking Point on the Stem in "lb x in"

Element: Water - Temperature: 59.9° F

11.1	SIZE Ø mm Ø inch	1/4" 10 0.39	3/8" 10 0.39	1/2" 15 0.59	3/4" 20 0.79	1" 25 0.98	1-1/4" 32 1.26	1-1/2" 40 1.57	2" 50 1.97	2-1/2" 63 2.48	3" 76 2.99	4" 100 3.94
CV	gal/min	9.3	11.6	19.7	47.4	78.7	142.3	229.1	335.4	601.5	983.1	1582
CM	N x m lb x in	1 9	1 9	3 27	5 44	6 53	7 62	10 89	13 115	16 142	20 177	30 266
CS	N x m lb x in	2 18	2 18	6 53	10 89	12 106	14 124	20 177	26 230	32 283	40 354	60 531
MT	N x m lb x in	10 89	10 89	10 89	24 213	24 213	45 399	90 797	90 797	280 2480	280 2480	550 4872

FC: Capacity is determined by the quantity in BTU/h of a gas of 0.64 SG which can be passed with a pressure drop equal to 0.3" water column

Element: Gas - Specific Gravity: 0.64

11.1	SIZE Ø mm Ø inch	1/4" 10 0.39	3/8" 10 0.39	1/2" 15 0.59	3/4" 20 0.79	1" 25 0.98	1-1/4" 32 1.26	1-1/2" 40 1.57	2" 50 1.97
FC	BTU/h	170,000	185,000	455,000	930,000	1,420,000	3,245,000	4,975,000	6,800,000
CM	N x m lb x in	1 9	1 9	3 27	5 44	6 53	7 62	10 89	13 115
CS	N x m lb x in	2 18	2 18	6 53	10 89	12 106	14 124	20 177	26 230
MT	N x m lb x in	10 89	10 89	10 89	24 213	24 213	45 399	90 797	90 797

FLOW AND PRESSURE DROP

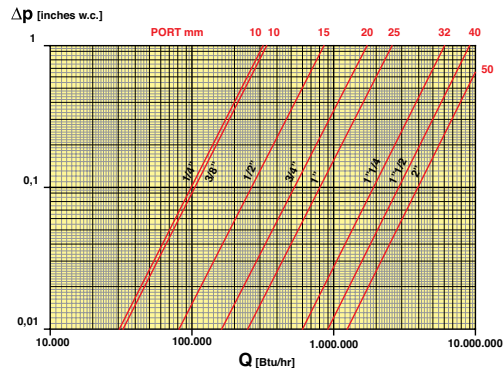
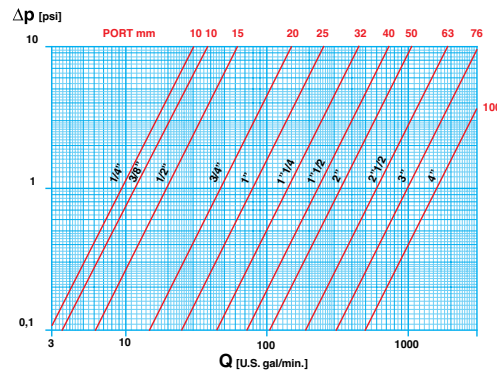

PRESSURE/TEMPERATURE RATINGS

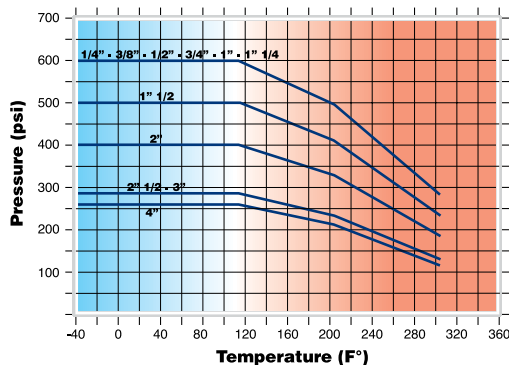

Working Pressure: 1/4" – 1-1/4" : 600 PSI

1-1/2" : 500 PSI

2" : 400 PSI

2-1/2" – 3" : 290 PSI

4" : 261 PSI

Max. Operating Temperature: Working Limit for Fluids -40° F – 302° F

Test Pressures: According to ISO 5208

Vacuum: the CIM 11.1 Ball Valve can be used for Vacuum: 2x10⁻⁵ PSI